

- **Integrated 0.15-Ω Power MOSFET**
- **7-V to 15-V Operation**
- **Digital-Programmable Current Limit from 0 A to 3 A**
- **100-μA I<sub>CC</sub> When Disabled**
- **Programmable On Time**
- **Programmable Start Delay**
- **Fixed 2% Duty Cycle**
- **Thermal Shutdown**
- **Fault-Output Indicator**
- **Maximum-Output Current Can Be Set to 1 A Above the Programmed-Fault Level or to a Full 4 A**
- **Power SOIC and TSSOP, Low Thermal Resistance Packaging**

**description**

The UCC3915 programmable hot swap power manager provides complete power-management, hot-swap capability, and circuit breaker functions. The only external component required to operate the device, other than power supply bypassing, is the fault-timing capacitor, C<sub>T</sub>. All control and housekeeping functions are integrated, and externally programmable. These include the fault current level, maximum output sourcing current, maximum fault time, and startup delay. In the event of a constant fault, the internal fixed 2% duty cycle ratio limits average output power.

The internal 4-bit DAC allows programming of the fault-level current from 0 A to 3 A with 0.25-A resolution. The IMAX control pin sets the maximum-sourcing current to 1 A above the trip level or to a full 4 A of output current for fast output capacitor charging. (continued)

**block diagram**

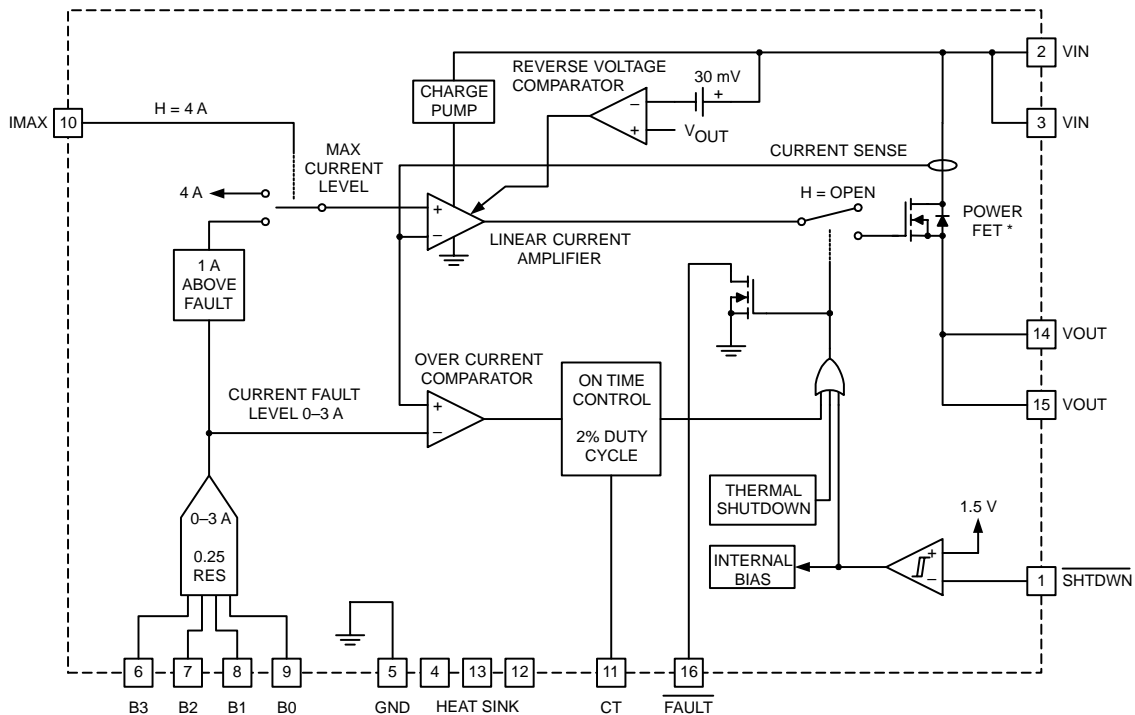

UDG-99174

NOTE: Pin numbers refer to DIL-16 and SOIC-16 packages.



Please be aware that an important notice concerning availability, standard warranty, and use in critical applications of Texas Instruments semiconductor products and disclaimers thereto appears at the end of this data sheet.

PRODUCTION DATA information is current as of publication date. Products conform to specifications per the terms of Texas Instruments standard warranty. Production processing does not necessarily include testing of all parameters.



POST OFFICE BOX 655303 • DALLAS, TEXAS 75265

Copyright © 2000, Texas Instruments Incorporated

# UCC2915, UCC3915 15-V PROGRAMMABLE HOT SWAP POWER MANAGER

SLUS198C – FEBRUARY 2000 - REVISED - JUNE 2001

## description (continued)

When the output current is below the fault level, the output MOSFET is switched on with a nominal ON resistance of 0.15  $\Omega$ . When the output current exceeds the fault level, but is less than the maximum-sourcing level, the output remains switched on, but the fault timer starts, charging CT. Once CT charges to a preset threshold, the switch is turned off, and remains off for 50 times the programmed fault time. When the output current reaches the maximum sourcing level, the MOSFET transitions from a switch to a constant current source.

The UCC3915 can be put into sleep mode, drawing only 100  $\mu$ A of supply current. Other features include an open-drain fault-output indicator, thermal shutdown, undervoltage lockout, 7-V to 15-V operation, and low-thermal resistance SOIC and TSSOP power packages.

## absolute maximum ratings over operating free-air temperature (unless otherwise noted)†

|                                       |                |
|---------------------------------------|----------------|
| VIN                                   | 15.5 V         |
| VOUT – VIN                            | .0.3 V         |
| FAULT sink current                    | 50 mA          |
| FAULT voltage                         | –0.3 V to 8 V  |
| Output current                        | Self limiting  |
| TTL input voltage                     | –0.3 to VIN    |
| Storage temperature, T <sub>stg</sub> | –65°C to 150°C |
| Junction temperature, T <sub>J</sub>  | –55°C to 150°C |
| Lead temperature (soldering, 10 sec.) | 300°C          |

† Stresses beyond those listed under “absolute maximum ratings” may cause permanent damage to the device. These are stress ratings only, and functional operation of the device at these or any other conditions beyond those indicated under “recommended operating conditions” is not implied. Exposure to absolute-maximum-rated conditions for extended periods may affect device reliability.

‡ Currents are positive into, negative out of the specified terminal. Consult Packaging Section of the *Interface Products Data Book* (TI Literature Number SLUD002) for thermal limitations and considerations of packages.

## package information

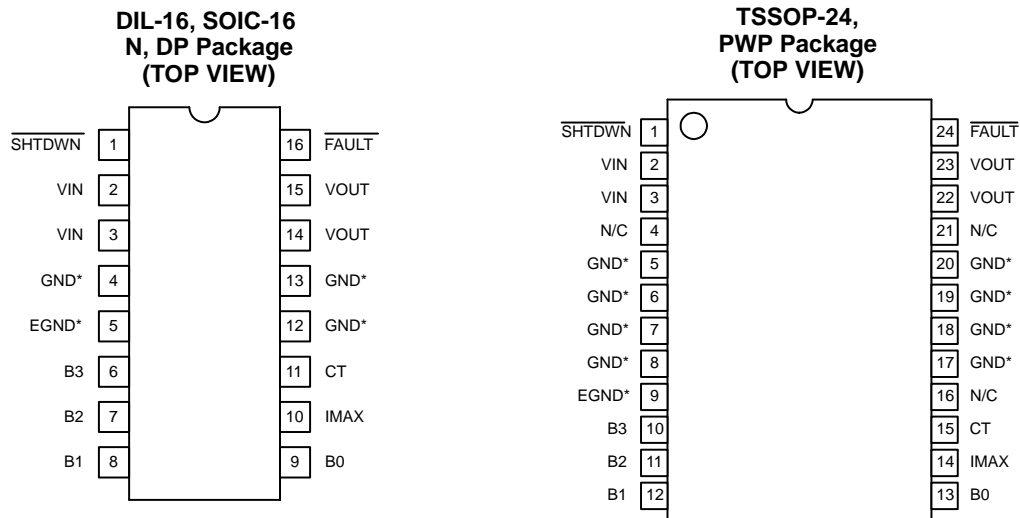

\*Pin 5 serves as lowest impedance to the electrical ground; Pins 4, 12, and 13 serve as heat sink/ground. These pins should be connected to large etch areas to help dissipate heat. For N Package, pins 4, 12, and 13 are N/C.

\*Pin 9 serves as lowest impedance to the electrical ground; other GND pins serve as heat sink/ground. These pins should be connected to large etch areas to help dissipate heat.

# UCC2915, UCC3915

## 15-V PROGRAMMABLE HOT SWAP POWER MANAGER

SLUS198C – FEBRUARY 2000 - REVISED - JUNE 2001

electrical characteristics, these specifications apply for  $T_A = -40^{\circ}\text{C}$  to  $85^{\circ}\text{C}$  for the UCC2915 and  $0^{\circ}\text{C}$  to  $70^{\circ}\text{C}$  for the UCC3915,  $V_{IN} = 12\text{ V}$ ,  $I_{MAX} = 0.4\text{ A}$ ,  $SHTDWN = 2.4\text{ V}$ ,  $T_A = T_J$ , (unless otherwise stated)

### supply

| PARAMETER           | TEST CONDITIONS                              | MIN | TYP | MAX  | UNITS         |
|---------------------|--|-----|-----|------|---------------|
| Voltage input range |  | 7.0 |     | 15.0 | V             |
| Supply current      |  |     | 1.0 | 2.0  | mA            |
| Sleep mode current  | $\overline{SHTDWN} = 0.2\text{ V}$ , no load |     | 100 | 150  | $\mu\text{A}$ |
| Output leakage      | $\overline{SHTDWN} = 0.2\text{ V}$           |     |     | 20   | $\mu\text{A}$ |

NOTE 1: All voltages are with respect to GND. Current is positive into and negative out of the specified terminal.

### output

| PARAMETER              | TEST CONDITIONS  | MIN | TYP  | MAX | UNITS              |
|------------------------|--|-----|------|-----|--------------------|
| Voltage drop           | $I_{OUT} = 1\text{ A}$ (10 V to 12 V)                              |     | 0.15 | 0.3 | V                  |
|                        | $I_{OUT} = 2\text{ A}$ (10 V to 12 V)                              |     | 0.3  | 0.6 | V                  |
|                        | $I_{OUT} = 3\text{ A}$ (10 V to 12 V)                              |     | 0.45 | 0.9 | V                  |
|                        | $I_{OUT} = 1\text{ A}$ , $V_{IN} = 7\text{ V}$ and $15\text{ V}$   |     | 0.2  | 0.4 | V                  |
|                        | $I_{OUT} = 2\text{ A}$ , $V_{IN} = 7\text{ V}$ and $15\text{ V}$   |     | 0.4  | 0.8 | V                  |
|                        | $I_{OUT} = 3\text{ A}$ , $V_{IN} = 7\text{ V}$ , $12\text{ V MAX}$ |     | 0.6  | 1.2 | V                  |
| Initial startup time   | See Note 2   |     | 100  |     | $\mu\text{s}$      |
| Short circuit response | See Note 2   |     | 100  |     | ns                 |
| Thermal shutdown       | See Note 2   |     | 165  |     | $^{\circ}\text{C}$ |
| Thermal hysteresis     | See Note 2   |     | 10   |     | $^{\circ}\text{C}$ |

NOTE 1: All voltages are with respect to GND. Current is positive into and negative out of the specified terminal.

NOTE 2: Ensured by design. Not production tested.

### DAC

| PARAMETER    | TEST CONDITIONS               | MIN  | TYP  | MAX  | UNITS |
|--------------|-------------------------------|------|------|------|-------|
| Trip current | Code = 0000–0011 (device off) |      |      |      |       |
|              | Code = 0100                   | 0.07 | 0.25 | 0.45 | A     |
|              | Code = 0101                   | 0.32 | 0.50 | 0.70 | A     |
|              | Code = 0110                   | 0.50 | 0.75 | 0.98 | A     |
|              | Code = 0111                   | 0.75 | 1.00 | 1.3  | A     |
|              | Code = 1000                   | 1.0  | 1.25 | 1.6  | A     |
|              | Code = 1001                   | 1.25 | 1.50 | 1.85 | A     |
|              | Code = 1010                   | 1.5  | 1.75 | 2.15 | A     |
|              | Code = 1011                   | 1.70 | 2.00 | 2.4  | A     |
|              | Code = 1100                   | 1.90 | 2.25 | 2.7  | A     |
|              | Code = 1101                   | 2.1  | 2.50 | 2.95 | A     |

NOTE 1: All voltages are with respect to GND. Current is positive into and negative out of the specified terminal.



# UCC2915, UCC3915

## 15-V PROGRAMMABLE HOT SWAP POWER MANAGER

SLUS198C – FEBRUARY 2000 - REVISED - JUNE 2001

electrical characteristics, these specifications apply for  $T_A = -40^{\circ}\text{C}$  to  $85^{\circ}\text{C}$  for the UCC2915 and  $0^{\circ}\text{C}$  to  $70^{\circ}\text{C}$  for the UCC3915,  $V_{IN} = 12\text{ V}$ ,  $I_{MAX} = 0.4\text{ V}$ ,  $SHTDWN = 2.4\text{ V}$ ,  $T_A = T_J$ , (unless otherwise stated)

### DAC (continued)

| PARAMETER  | TEST CONDITIONS                               | MIN  | TYP  | MAX  | UNITS |
|--|---|------|------|------|-------|
| Trip current                                       | Code = 1110                                   | 2.30 | 2.75 | 3.25 | A     |
|  | Code = 1111                                   | 2.50 | 3.0  | 3.50 | A     |
| Max output current over trip (current source mode) | Code = 0100 to 1111, $I_{MAX} = 0\text{ V}$   | 0.35 | 1.0  | 1.65 | A     |
| Max output current (current source mode)           | Code = 0100 to 1111, $I_{MAX} = 2.4\text{ V}$ | 3.0  | 4.0  | 5.2  | A     |

NOTE 1: All voltages are with respect to GND. Current is positive into and negative out of the specified terminal.

### fault timer

| PARAMETER            | TEST CONDITIONS         | MIN  | TYP  | MAX  | UNITS         |
|----------------------|-------------------------|------|------|------|---------------|
| CT charge current    | $V_{CT} = 1.0\text{ V}$ | -83  | -62  | -47  | $\mu\text{A}$ |
| CT discharge current | $V_{CT} = 1.0\text{ V}$ | 0.8  | 1.2  | 1.8  | $\mu\text{A}$ |
| Output duty cycle    | $V_{OUT} = 0\text{ V}$  | 1.0% | 1.9% | 3.3% |               |
| CT fault threshold   |                         | 1.2  | 1.5  | 1.7  | V             |
| CT reset threshold   |                         | 0.4  | 0.5  | 0.6  | V             |

NOTE 1: All voltages are with respect to GND. Current is positive into and negative out of the specified terminal.

### shutdown

| PARAMETER           | TEST CONDITIONS | MIN | TYP | MAX | UNITS |
|---------------------|-----------------|-----|-----|-----|-------|
| Shutdown threshold  |                 | 1.1 | 1.5 | 1.9 | V     |
| Shutdown hysteresis |                 |     | 150 |     | mV    |
| Input current       |                 |     | 100 | 500 | nA    |

NOTE 1: All voltages are with respect to GND. Current is positive into and negative out of the specified terminal.

### open drain output ( $\overline{\text{FAULT}}$ )

| PARAMETER                 | TEST CONDITIONS                        | MIN | TYP | MAX | UNITS         |
|---------------------------|--|-----|-----|-----|---------------|
| High level output current | $\overline{\text{FAULT}} = 5\text{ V}$ |     |     | 250 | $\mu\text{A}$ |
| Low level output voltage  | $I_{OUT} = 5\text{ mA}$                |     | 0.2 | 0.8 | V             |

NOTE 1: All voltages are with respect to GND. Current is positive into and negative out of the specified terminal.

### TTL input dc characteristics

| PARAMETER              | TEST CONDITIONS         | MIN | TYP | MAX | UNITS         |
|------------------------|-------------------------|-----|-----|-----|---------------|
| TTL input voltage high |                         | 2.0 |     |     | V             |
| TTL input voltage low  |                         |     |     | 0.8 | V             |
| TTL input high current | $V_{IH} = 2.4\text{ V}$ |     | 3   | 10  | $\mu\text{A}$ |
| TTL input low current  | $V_{IL} = 0.4\text{ V}$ |     |     | 1   | $\mu\text{A}$ |

NOTE 1: All voltages are with respect to GND. Current is positive into and negative out of the specified terminal.



# UCC2915, UCC3915

## 15-V PROGRAMMABLE HOT SWAP POWER MANAGER

SLUS198C – FEBRUARY 2000 - REVISED - JUNE 2001

### pin descriptions

**B0 – B3:** These pins provide digital input to the DAC, which sets the fault-current threshold. They can be used to provide a digital soft-start and adaptive-current limiting.

**CT:** A capacitor connected to ground sets the maximum-fault time. The maximum-fault time must be more than the time required to charge the external capacitance in one cycle. The maximum-fault time is defined as  $T_{\text{FAULT}} = 16.1 \times 10^3 \times C_T$ . Once the fault time is reached the output will shutdown for a time given by  $T_{\text{SD}} = 833 \times 10^3 \times C_T$ , this equates to a 1.9% duty cycle.

**FAULT:** Open-drain output, which pulls low upon any fault or interrupt condition, or thermal shutdown.

**IMAX:** When this pin is set to a logic low, the maximum-sourcing current will always be 1 A above the programmed-fault level. When set to a logic high, the maximum-sourcing current will be a constant 4 A for applications which require fast charging of load capacitance.

**SHTDWN:** When this pin is brought to a logic low, the IC is put into a sleep mode drawing typically less than 100  $\mu\text{A}$  of  $I_{\text{CC}}$ . The input threshold is hysteretic, allowing the user to program a startup delay with an external RC circuit.

**VIN:** Input voltage to the UCC3915. The recommended voltage range is 7 V to 15 V. Both VIN pins should be connected together and connected to the power source.

**VOUT:** Output voltage from the UCC3915. Both VOUT pins should be connected together and connected to the load. When switched the output voltage will be approximately  $V_{\text{IN}} - (0.15 \Omega \times I_{\text{OUT}})$ . VOUT must not exceed VIN by greater than 0.3 V.

### APPLICATION INFORMATION

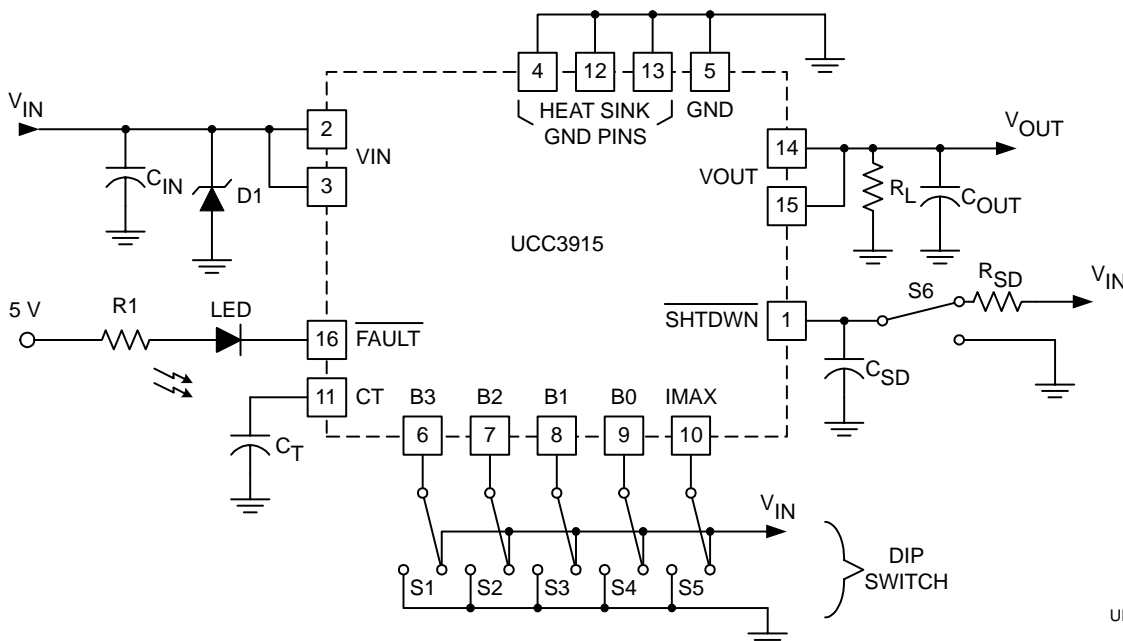

UDG-99175

**Figure 1. Evaluation Circuit**

# UCC2915, UCC3915 15-V PROGRAMMABLE HOT SWAP POWER MANAGER

SLUS198C – FEBRUARY 2000 - REVISED - JUNE 2001

## APPLICATION INFORMATION

### protecting the UCC3915 from voltage transients

The parasitic inductance associated with the power distribution can cause a voltage spike at  $V_{IN}$  if the load current is suddenly interrupted by the UCC3915. It is important to limit the peak of this spike to less than 15 V to prevent damage to the UCC3915. This voltage spike can be minimized by:

- Reducing the power distribution inductance (e.g., twist the positive (+) and negative (-) leads of the power supply feeding  $V_{IN}$ , locate the power supply close to the UCC3915 or use PCB power and ground planes).
- Decoupling  $V_{IN}$  with a capacitor,  $C_{IN}$  (refer to Figure 1), located close to the  $V_{IN}$  pins. This capacitor is typically 1  $\mu$ F or less to limit the inrush current.
- Clamping the voltage at  $V_{IN}$  below 15 V with a Zener diode, D1 (refer to Figure 1), located close to the  $V_{IN}$  pins.

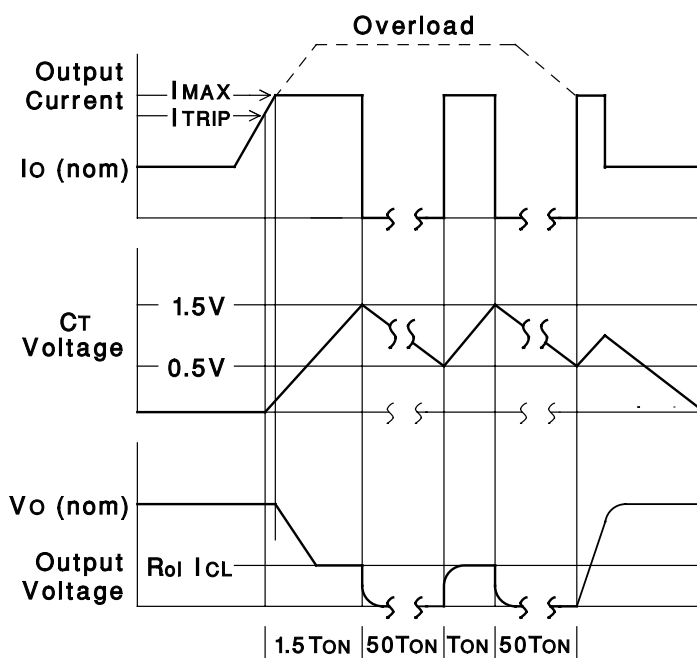

Figure 2. Load Current, Timing-Capacitor Voltage, and Output Voltage of the UCC3915 Under Fault Conditions

### estimating maximum load capacitance

For hot-swap applications, the rate at which the total output capacitance can be charged depends on the maximum-output current available and the nature of the load. For a constant-current, current-limited application, the output will come up if the load asks for less than the maximum available short-circuit current.

To ensure recovery of a duty cycle from a short-circuited load condition, there is a maximum total output capacitance which can be charged for a given unit on time (fault time). The design value of on or fault time can be adjusted by changing the timing capacitor  $C_T$ .

### APPLICATION INFORMATION

For worst-case constant-current load of value just less than the trip limit;  $C_{OUT(max)}$  can be estimated from:

$$C_{OUT(max)} \approx (I_{MAX} - I_{LOAD}) \times \left( \frac{16.1 \times 10^3 \times C_T}{V_{OUT}} \right)$$

Where  $V_{OUT}$  is the output voltage.

For a resistive load of value  $R_L$ , the value of  $C_{OUT(max)}$  can be estimated from:

$$C_{OUT(max)} \approx \left[ \frac{16.1 \times 10^3 \times C_T}{R_L \times \ln \left[ \frac{1}{1 - \frac{V_{OUT}}{I_{MAX} \times R_L}} \right]} \right]$$

Long  $C_T$  times must consider the maximum temperature. Thermal shutdown protection may be the limiting fault time.

#### **safety recommendations**

Although the UCC3915 is designed to provide system protection for all fault conditions, all integrated circuits can ultimately fail short. For this reason, if the UCC3915 is intended for use in safety-critical applications where UL or some other safety rating is required, a redundant safety device such as a fuse should be placed in series with the device. The UCC3915 will prevent the fuse from blowing for virtually all fault conditions, increasing system reliability and reducing maintenance cost, in addition to providing the hot-swap benefits of the device.

**PACKAGING INFORMATION**

| Orderable Device | Status<br>(1) | Package Type | Package Drawing | Pins | Package Qty | Eco Plan<br>(2)         | Lead/Ball Finish<br>(6) | MSL Peak Temp<br>(3) | Op Temp (°C) | Device Marking<br>(4/5) | Samples                 |
|------------------|---------------|--------------|-----------------|------|-------------|-------------------------|-------------------------|----------------------|--------------|-------------------------|-------------------------|
| UCC2915DP        | ACTIVE        | SOIC         | D               | 16   | 40          | Green (RoHS & no Sb/Br) | CU NIPDAU               | Level-2-260C-1 YEAR  | -40 to 85    | UCC2915DP               | <a href="#">Samples</a> |
| UCC2915DPG4      | ACTIVE        | SOIC         | D               | 16   | 40          | Green (RoHS & no Sb/Br) | CU NIPDAU               | Level-2-260C-1 YEAR  | -40 to 85    | UCC2915DP               | <a href="#">Samples</a> |
| UCC3915DP        | ACTIVE        | SOIC         | D               | 16   | 40          | Green (RoHS & no Sb/Br) | CU NIPDAU               | Level-2-260C-1 YEAR  | 0 to 70      | UCC3915DP               | <a href="#">Samples</a> |
| UCC3915DPG4      | ACTIVE        | SOIC         | D               | 16   | 40          | Green (RoHS & no Sb/Br) | CU NIPDAU               | Level-2-260C-1 YEAR  | 0 to 70      | UCC3915DP               | <a href="#">Samples</a> |
| UCC3915DPTR      | ACTIVE        | SOIC         | D               | 16   | 2500        | Green (RoHS & no Sb/Br) | CU NIPDAU               | Level-2-260C-1 YEAR  | 0 to 70      | UCC3915DP               | <a href="#">Samples</a> |
| UCC3915PWP       | ACTIVE        | TSSOP        | PW              | 24   | 60          | Green (RoHS & no Sb/Br) | CU NIPDAU               | Level-2-260C-1 YEAR  | 0 to 70      | UCC3915PWP              | <a href="#">Samples</a> |
| UCC3915PWPTR     | ACTIVE        | TSSOP        | PW              | 24   | 2000        | Green (RoHS & no Sb/Br) | CU NIPDAU               | Level-2-260C-1 YEAR  | 0 to 70      | UCC3915PWP              | <a href="#">Samples</a> |
| UCC3915PWPTRG4   | ACTIVE        | TSSOP        | PW              | 24   | 2000        | Green (RoHS & no Sb/Br) | CU NIPDAU               | Level-2-260C-1 YEAR  | 0 to 70      | UCC3915PWP              | <a href="#">Samples</a> |

(1) The marketing status values are defined as follows:

**ACTIVE:** Product device recommended for new designs.

**LIFEBUY:** TI has announced that the device will be discontinued, and a lifetime-buy period is in effect.

**NRND:** Not recommended for new designs. Device is in production to support existing customers, but TI does not recommend using this part in a new design.

**PREVIEW:** Device has been announced but is not in production. Samples may or may not be available.

**OBSOLETE:** TI has discontinued the production of the device.

(2) Eco Plan - The planned eco-friendly classification: Pb-Free (RoHS), Pb-Free (RoHS Exempt), or Green (RoHS & no Sb/Br) - please check <http://www.ti.com/productcontent> for the latest availability information and additional product content details.

**TBD:** The Pb-Free/Green conversion plan has not been defined.

**Pb-Free (RoHS):** TI's terms "Lead-Free" or "Pb-Free" mean semiconductor products that are compatible with the current RoHS requirements for all 6 substances, including the requirement that lead not exceed 0.1% by weight in homogeneous materials. Where designed to be soldered at high temperatures, TI Pb-Free products are suitable for use in specified lead-free processes.

**Pb-Free (RoHS Exempt):** This component has a RoHS exemption for either 1) lead-based flip-chip solder bumps used between the die and package, or 2) lead-based die adhesive used between the die and leadframe. The component is otherwise considered Pb-Free (RoHS compatible) as defined above.

**Green (RoHS & no Sb/Br):** TI defines "Green" to mean Pb-Free (RoHS compatible), and free of Bromine (Br) and Antimony (Sb) based flame retardants (Br or Sb do not exceed 0.1% by weight in homogeneous material)

(3) MSL, Peak Temp. - The Moisture Sensitivity Level rating according to the JEDEC industry standard classifications, and peak solder temperature.

(4) There may be additional marking, which relates to the logo, the lot trace code information, or the environmental category on the device.

(5) Multiple Device Markings will be inside parentheses. Only one Device Marking contained in parentheses and separated by a "~" will appear on a device. If a line is indented then it is a continuation of the previous line and the two combined represent the entire Device Marking for that device.

(6) Lead/Ball Finish - Orderable Devices may have multiple material finish options. Finish options are separated by a vertical ruled line. Lead/Ball Finish values may wrap to two lines if the finish value exceeds the maximum column width.

**Important Information and Disclaimer:**The information provided on this page represents TI's knowledge and belief as of the date that it is provided. TI bases its knowledge and belief on information provided by third parties, and makes no representation or warranty as to the accuracy of such information. Efforts are underway to better integrate information from third parties. TI has taken and continues to take reasonable steps to provide representative and accurate information but may not have conducted destructive testing or chemical analysis on incoming materials and chemicals. TI and TI suppliers consider certain information to be proprietary, and thus CAS numbers and other limited information may not be available for release.

In no event shall TI's liability arising out of such information exceed the total purchase price of the TI part(s) at issue in this document sold by TI to Customer on an annual basis.

**TAPE AND REEL INFORMATION**
**REEL DIMENSIONS**

**TAPE DIMENSIONS**

|    |   |
|----|---|
| A0 | Dimension designed to accommodate the component width     |
| B0 | Dimension designed to accommodate the component length    |
| K0 | Dimension designed to accommodate the component thickness |
| W  | Overall width of the carrier tape                         |
| P1 | Pitch between successive cavity centers                   |

**TAPE AND REEL INFORMATION**

\*All dimensions are nominal

| Device       | Package Type | Package Drawing | Pins | SPQ  | Reel Diameter (mm) | Reel Width W1 (mm) | A0 (mm) | B0 (mm) | K0 (mm) | P1 (mm) | W (mm) | Pin1 Quadrant |
|--------------|--------------|-----------------|------|------|--------------------|--------------------|---------|---------|---------|---------|--------|---------------|
| UCC3915DPTR  | SOIC         | D               | 16   | 2500 | 330.0              | 16.4               | 6.5     | 10.3    | 2.1     | 8.0     | 16.0   | Q1            |
| UCC3915PWPTR | TSSOP        | PW              | 24   | 2000 | 330.0              | 16.4               | 6.95    | 8.3     | 1.6     | 8.0     | 16.0   | Q1            |

**TAPE AND REEL BOX DIMENSIONS**

\*All dimensions are nominal

| Device       | Package Type | Package Drawing | Pins | SPQ  | Length (mm) | Width (mm) | Height (mm) |
|--------------|--------------|-----------------|------|------|-------------|------------|-------------|
| UCC3915DPTR  | SOIC         | D               | 16   | 2500 | 367.0       | 367.0      | 38.0        |
| UCC3915PWPTR | TSSOP        | PW              | 24   | 2000 | 367.0       | 367.0      | 38.0        |

D (R-PDSO-G16)

PLASTIC SMALL OUTLINE



- NOTES:
- A. All linear dimensions are in inches (millimeters).
  - B. This drawing is subject to change without notice.
  - C. Body length does not include mold flash, protrusions, or gate burrs. Mold flash, protrusions, or gate burrs shall not exceed 0.006 (0,15) each side.
  - D. Body width does not include interlead flash. Interlead flash shall not exceed 0.017 (0,43) each side.
  - E. Reference JEDEC MS-012 variation AC.

N (R-PDIP-T\*\*)

PLASTIC DUAL-IN-LINE PACKAGE

16 PINS SHOWN



- NOTES:
- A. All linear dimensions are in inches (millimeters).
  - B. This drawing is subject to change without notice.
  - (C) Falls within JEDEC MS-001, except 18 and 20 pin minimum body length (Dim A).
  - (D) The 20 pin end lead shoulder width is a vendor option, either half or full width.

# MECHANICAL DATA

PWP (R-PDSO-G24)

PowerPAD™ PLASTIC SMALL OUTLINE

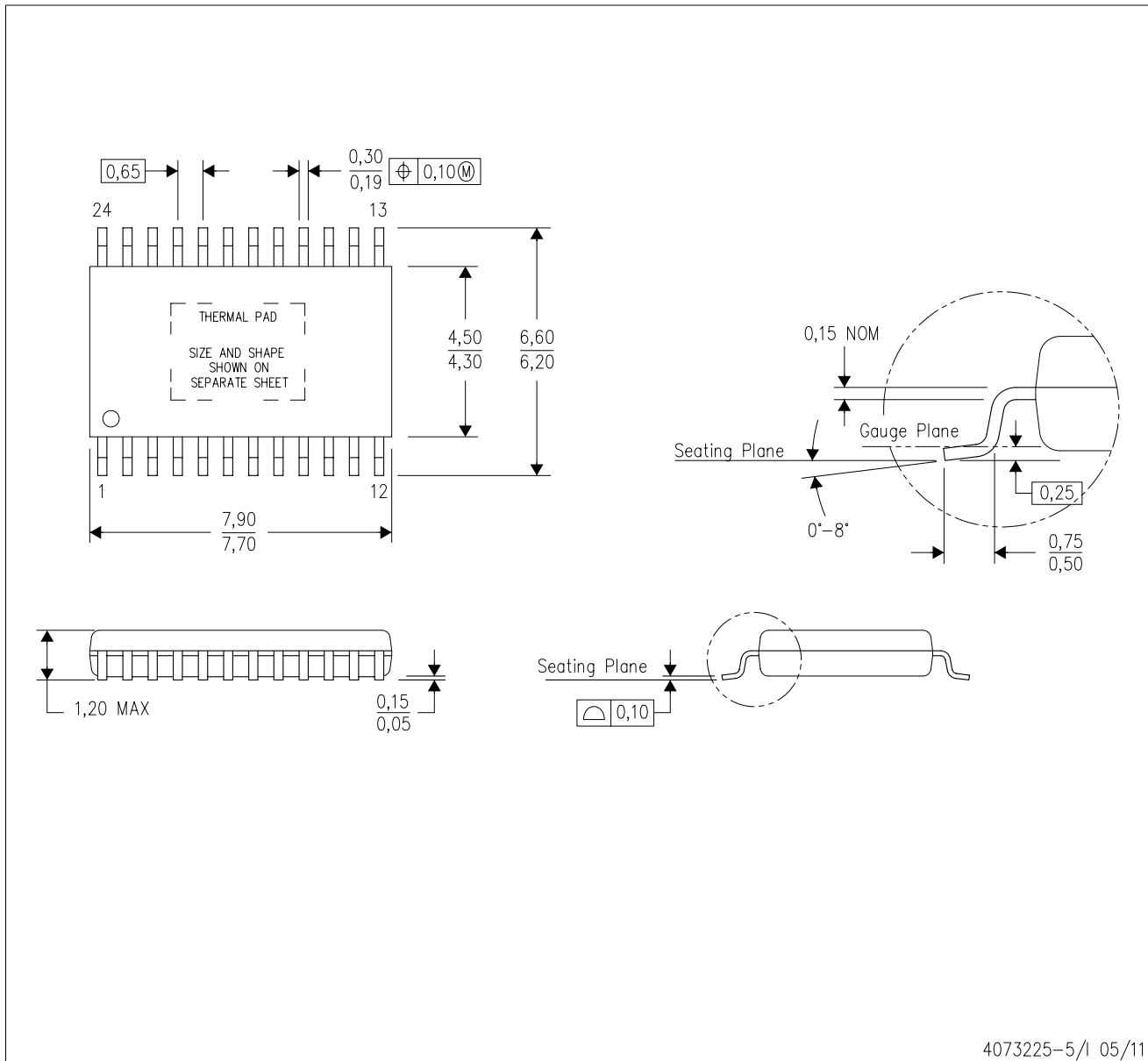

4073225-5/1 05/11

- NOTES:
- All linear dimensions are in millimeters.
  - This drawing is subject to change without notice.
  - Body dimensions do not include mold flash or protrusions. Mold flash and protrusion shall not exceed 0.15 per side.
  - This package is designed to be soldered to a thermal pad on the board. Refer to Technical Brief, PowerPad Thermally Enhanced Package, Texas Instruments Literature No. SLMA002 for information regarding recommended board layout. This document is available at [www.ti.com](http://www.ti.com) <<http://www.ti.com>>.
  - See the additional figure in the Product Data Sheet for details regarding the exposed thermal pad features and dimensions.
  - Falls within JEDEC MO-153

PowerPAD is a trademark of Texas Instruments.

## IMPORTANT NOTICE

Texas Instruments Incorporated (TI) reserves the right to make corrections, enhancements, improvements and other changes to its semiconductor products and services per JESD46, latest issue, and to discontinue any product or service per JESD48, latest issue. Buyers should obtain the latest relevant information before placing orders and should verify that such information is current and complete.

TI's published terms of sale for semiconductor products (<http://www.ti.com/sc/docs/stdterms.htm>) apply to the sale of packaged integrated circuit products that TI has qualified and released to market. Additional terms may apply to the use or sale of other types of TI products and services.

Reproduction of significant portions of TI information in TI data sheets is permissible only if reproduction is without alteration and is accompanied by all associated warranties, conditions, limitations, and notices. TI is not responsible or liable for such reproduced documentation. Information of third parties may be subject to additional restrictions. Resale of TI products or services with statements different from or beyond the parameters stated by TI for that product or service voids all express and any implied warranties for the associated TI product or service and is an unfair and deceptive business practice. TI is not responsible or liable for any such statements.

Buyers and others who are developing systems that incorporate TI products (collectively, "Designers") understand and agree that Designers remain responsible for using their independent analysis, evaluation and judgment in designing their applications and that Designers have full and exclusive responsibility to assure the safety of Designers' applications and compliance of their applications (and of all TI products used in or for Designers' applications) with all applicable regulations, laws and other applicable requirements. Designer represents that, with respect to their applications, Designer has all the necessary expertise to create and implement safeguards that (1) anticipate dangerous consequences of failures, (2) monitor failures and their consequences, and (3) lessen the likelihood of failures that might cause harm and take appropriate actions. Designer agrees that prior to using or distributing any applications that include TI products, Designer will thoroughly test such applications and the functionality of such TI products as used in such applications.

TI's provision of technical, application or other design advice, quality characterization, reliability data or other services or information, including, but not limited to, reference designs and materials relating to evaluation modules, (collectively, "TI Resources") are intended to assist designers who are developing applications that incorporate TI products; by downloading, accessing or using TI Resources in any way, Designer (individually or, if Designer is acting on behalf of a company, Designer's company) agrees to use any particular TI Resource solely for this purpose and subject to the terms of this Notice.

TI's provision of TI Resources does not expand or otherwise alter TI's applicable published warranties or warranty disclaimers for TI products, and no additional obligations or liabilities arise from TI providing such TI Resources. TI reserves the right to make corrections, enhancements, improvements and other changes to its TI Resources. TI has not conducted any testing other than that specifically described in the published documentation for a particular TI Resource.

Designer is authorized to use, copy and modify any individual TI Resource only in connection with the development of applications that include the TI product(s) identified in such TI Resource. NO OTHER LICENSE, EXPRESS OR IMPLIED, BY ESTOPPEL OR OTHERWISE TO ANY OTHER TI INTELLECTUAL PROPERTY RIGHT, AND NO LICENSE TO ANY TECHNOLOGY OR INTELLECTUAL PROPERTY RIGHT OF TI OR ANY THIRD PARTY IS GRANTED HEREIN, including but not limited to any patent right, copyright, mask work right, or other intellectual property right relating to any combination, machine, or process in which TI products or services are used. Information regarding or referencing third-party products or services does not constitute a license to use such products or services, or a warranty or endorsement thereof. Use of TI Resources may require a license from a third party under the patents or other intellectual property of the third party, or a license from TI under the patents or other intellectual property of TI.

TI RESOURCES ARE PROVIDED "AS IS" AND WITH ALL FAULTS. TI DISCLAIMS ALL OTHER WARRANTIES OR REPRESENTATIONS, EXPRESS OR IMPLIED, REGARDING RESOURCES OR USE THEREOF, INCLUDING BUT NOT LIMITED TO ACCURACY OR COMPLETENESS, TITLE, ANY EPIDEMIC FAILURE WARRANTY AND ANY IMPLIED WARRANTIES OF MERCHANTABILITY, FITNESS FOR A PARTICULAR PURPOSE, AND NON-INFRINGEMENT OF ANY THIRD PARTY INTELLECTUAL PROPERTY RIGHTS. TI SHALL NOT BE LIABLE FOR AND SHALL NOT DEFEND OR INDEMNIFY DESIGNER AGAINST ANY CLAIM, INCLUDING BUT NOT LIMITED TO ANY INFRINGEMENT CLAIM THAT RELATES TO OR IS BASED ON ANY COMBINATION OF PRODUCTS EVEN IF DESCRIBED IN TI RESOURCES OR OTHERWISE. IN NO EVENT SHALL TI BE LIABLE FOR ANY ACTUAL, DIRECT, SPECIAL, COLLATERAL, INDIRECT, PUNITIVE, INCIDENTAL, CONSEQUENTIAL OR EXEMPLARY DAMAGES IN CONNECTION WITH OR ARISING OUT OF TI RESOURCES OR USE THEREOF, AND REGARDLESS OF WHETHER TI HAS BEEN ADVISED OF THE POSSIBILITY OF SUCH DAMAGES.

Unless TI has explicitly designated an individual product as meeting the requirements of a particular industry standard (e.g., ISO/TS 16949 and ISO 26262), TI is not responsible for any failure to meet such industry standard requirements.

Where TI specifically promotes products as facilitating functional safety or as compliant with industry functional safety standards, such products are intended to help enable customers to design and create their own applications that meet applicable functional safety standards and requirements. Using products in an application does not by itself establish any safety features in the application. Designers must ensure compliance with safety-related requirements and standards applicable to their applications. Designer may not use any TI products in life-critical medical equipment unless authorized officers of the parties have executed a special contract specifically governing such use. Life-critical medical equipment is medical equipment where failure of such equipment would cause serious bodily injury or death (e.g., life support, pacemakers, defibrillators, heart pumps, neurostimulators, and implantables). Such equipment includes, without limitation, all medical devices identified by the U.S. Food and Drug Administration as Class III devices and equivalent classifications outside the U.S.

TI may expressly designate certain products as completing a particular qualification (e.g., Q100, Military Grade, or Enhanced Product). Designers agree that it has the necessary expertise to select the product with the appropriate qualification designation for their applications and that proper product selection is at Designers' own risk. Designers are solely responsible for compliance with all legal and regulatory requirements in connection with such selection.

Designer will fully indemnify TI and its representatives against any damages, costs, losses, and/or liabilities arising out of Designer's non-compliance with the terms and provisions of this Notice.